

# MONITORING SYSTEM OF AQUICULTURE WITH AUTOMATIC CONTROL SYSTEM USING ARM 7

Bodepudi SrinivasaRao, U.Jyothi Kameswari

*Department of ECM,K.L.University,A.P, India*

**Abstract**— The importance of water quality in Aquaculture and design an environmental factors monitoring system with Automatic control system. This monitoring system consists of PC host computer, slave computer in which the ARM7 Controller. The PC will used to settle the system, controll parameters, data processing, analysis and display. the other one is a slave computer, whose core is ARM7 Controller. Slave computer can measure and control the environmental factors of breeding system, that is, it can convert the collected data and store it as digital signal. Slave computer has data collecting module, data storing module, control module, power module, display module and Automatic control system. The slave computer is a close-loop control system, so that, it can individually accomplish environment factors Like Temperature, PH, dissolved oxygen, etc., measured. The wireless communication module is used to transfer data between host computer and slave computer. This system can realize control of the aquaculture environment factors, With the help of expert system, the system can achieve real-time monitoring, data collection, read, store and compared with the set points. If these values exceed their corresponding set points, the system displays the fault indication message on the LCD with sound alarming. After alarming once rising problem Automatic control motors are automatically ON, this env-factors to reach set points, Motors are Automatically OFF. So as to realize Energy saving, Safe, increase output, Lower the labour intensity and improve efficiency.

**Keywords**— Aquaculture, Real-Time monitoring, ARM, Expert system, Micro computer, Control motors.

## 1. INTRODUCTION

Water quality will directly affect the growth of aquaculture objects which affects the production and economic benefits. In the promotion of health culture concept and environment-friendly aquaculture, it has greater demands on water quality management [1]. In the introduction a definition of monitoring suggested that monitoring was for compliance with regulatory standards for protection and safeguarding environmental quality. This is true and forms the basis for monitoring, but other reasons are also important. The aquaculture industry has an important "stakeholder" interest in environmental quality. As pointed out earlier water quality (in particular) is of essential importance in maintaining the health of the cultured resource. This is true whether the reason be for optimization of fish growth to legal liability in case of litigation due to unacceptable environmental change which affects other resource users Environmental monitoring is therefore an

important part of fish farm management. The continuous and real-time automatic monitoring of water parameters will not only lead to a high quality aquaculture management but also provide accurate experimental data which help to optimize breeding process reduce farming costs and improve breeding efficiency [2]. Therefore it is meaningful to establish monitoring system. PC and ARM7 controller system are used as the host computer and slave computer respectively of the whole system which has a function of automatically detecting and controlling the temperature, PH, dissolved oxygen and other environmental factors. These analytically results can help to provide a suitable environment for aquatic products, the implementation of automatic feeding, science culture and other functions, safe, high quality, highyield purposes.

## 2. SCOPE AND OBJECTIVE

The main Objective of this Paper is to Monitor the Multi-environmental factors Like Temperature, PH, dissolved oxygen, etc., of breeding system. that is it can convert the collected data and store it as digital signal. the system can achieve real-time monitoring, data collection, read, store and compared with the set points. If these values exceed their corresponding set points, the system displays the fault indication message on the LCD with sound alarming. After alarming once problem rising Automatic control motors are automaticall ON, later env-factors to reach set points, Motors are Automatically OFF

## 3. RESEARCH BACKGROUND

Aqua-cultured fish is one of the dominant export products in Vietnam. The development of this sector is a major source of foreign currency and employment opportunity. The success of the sector encourages both local and foreign investment. Vietnam has a coastline of more than 3,200 km long with over 3000 islands, a wealth of natural inland water bodies (lakes and rivers) and area of ponds and seasonal flooded grounds[3]. Today Vietnam is one of the top seafood exporters in the world, with products from aquaculture accounting for more than 40% in volume of seafood produced and almost 60% in value (MOFI, 2006).

## 4. HARDWARE DESCRIPTION

This monitoring system consists of PC host computer, slave computer in which the ARM7 controller from ARM Company is used as the core and a wireless module F21DM to transfer

data. Figure-1 is the structure schematics of system. Slave computer can measure and control the environmental factors of breeding system, that is, it can convert the collected data and store it as digital signal. Output corresponding signals after comparing collected data with designed value which will be transferred to host computer by F21DM module. The PC will used to settle the system, controll parameters, data processing, analysis and display.

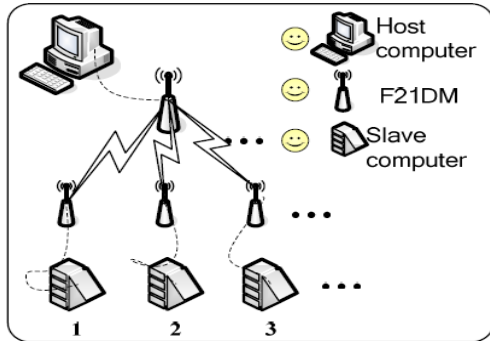

Figure-1: Structure of breeding Environment Monitoring System

4.1. Hardware Design of Slave Computer

It discusses the design and working of the design with the help of block diagram and circuit diagram and explanation of circuit diagram in detail. It explains the features, timer programming, serial communication, of ARM7 controller. It also explains the various modules used in this design [4]. The slave computer can individually accomplish environment factors measurement, data analysis, display with alarming and to controlling Automatically, which is a close-loop control system. Figure-2 is the structure schematics of Hardware diagram of slave computer. It consists of power supply unit, ARM7 controller, sensor module, Communication module display unit and automatic control system.

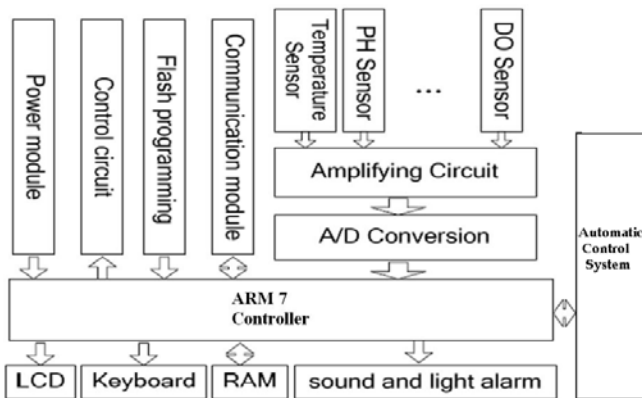

Figure-2: Hardware diagram of slave computer

A. ARM 7:

ARM is a 32-bit RISC processor architecture currently being developed by the ARM corporation. The business model behind ARM is based on licensing the ARM architecture to

companies that want to manufacture ARM-based CPU's or system-on-a-chip products. The Implementation license provides complete information required to design and manufacture integrated circuits containing an ARM processor core. ARM licenses two types of cores: soft cores and hard cores. A hard core is optimised for a specific manufacturing process, while a soft core can be used in any process but is less optimised. The architecture license enables the licensee to develop their own processors compliant with the ARM ISA. ARM processors possess a unique combination of features that makes ARM the most popular embedded architecture today. First, ARM cores are very simple compared to most other general-purpose processors, which means that they can be manufactured using a comparatively small number of transistors, leaving plenty of space on the chip for application-specific macrocells. A typical ARM chip can contain several peripheral controllers, a digital signal processor, and some amount of on-chip memory, along with an ARM core. Second, both ARM ISA and pipeline design are aimed at minimising energy consumption a critical requirement in mobile embedded systems. Third, the ARM architecture is highly modular: the only mandatory component of an ARM processor is the integer pipeline; all other components, including caches, MMU, floating point and other co-processors are optional, which gives a lot of flexibility in building application-specific ARM-based processors. Finally, while being small and low-power, ARM processors provide high performance for embedded applications[5].

Features are: 32-bit RISC-processor core (32-bit instructions); 37 pieces of 32-bit integer registers (16 available); Pipelined (ARM7: 3 stages); High Code density; Mostly Single-cycle execution; 8 / 16 / 32-bit data types; Speed 1Mhz to 1.25Ghz; simple structure, reasonably good speed and power consumption ratio.

B. Sensors Module:

- ① *GPP011 PH meter* to measure the value of PH which is a kind of immersion probe, type of GPE02P, has the precise of ±0.01pH, the range of output voltage is 0~5V, has a power of 2.5w.
- ② *RY952 Oxygen sensor* is used to measure the oxygen. It has a precise of 0.01mg/L, range of measurement is 0~20mg/L, the range of output voltage in air is 15~20mV, response time is less than 20s.
- ③ *LM35 Temperature sensor* is used to measure temperature. The input voltage is +15V. The high resistor current resource is changing with a speed of 1µA/°C .
- ④ *WK-1 Portable Water Ammonia Detector* is used to measure the content of Ammonia. The range of output voltage is -2V~+2V.

C. Wireless Communication Module:

The wireless communication module is used to transfer data because there are many problems in practice with wire communication such that increasing the complexity and the maintenance cost and reduce the flexibility of slave computer with wire communication [6]. The transparent data

transmission is used by F21DM, the users do not need to change the origin program and connecting. It can transfer a distance of 10 kilometre. This module has TTL, RS232, RS483 interfaces. The system uses Q-type communication, so that the time of data sending and receiving is staggered. The way of connection is bus connection between upper and lower computer under the premise of considering communication delay.

**D. Power Supply Module:**

The input to the circuit is applied from the regulated power supply. The a.c. input i.e., 230V from the mains supply is step down by the transformer to 12V and is fed to a rectifier. The output obtained from the rectifier is a pulsating d.c voltage. So in order to get a pure d.c voltage, the output voltage from the rectifier is fed to a filter to remove any a.c components present even after rectification. Now, this voltage is given to a voltage regulator to obtain a pure constant dc voltage. below fig-3 shows power supply module.

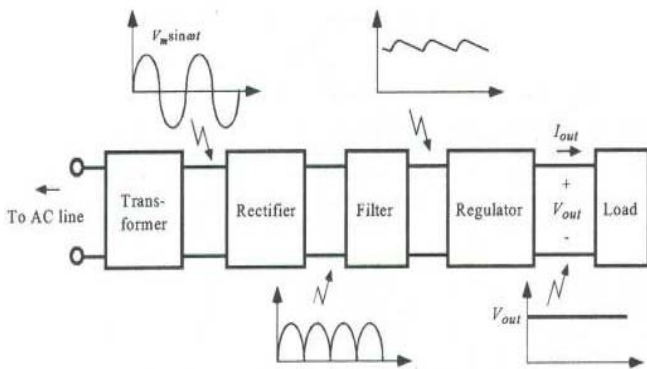

Figure-3: Components Of Regulated Power Supply

**E. Automatic Control Motor:**

The slave computer can individually accomplish environment factors measurement, data analysis, display the environmental Factors and over problem has been rising to play automatic sound alarming with Levels. This levels follow Automatic ON / OFF water pumps & Air pumps. an automatic pump means that a switch is wired to the sump pump to turn it on or off at appropriate water levels and it's Follow Max. & Min. value of Environment factors[7]. It maintained by ARM controllers and automatic control system. Figure-4 shown images of water pump and Air pump.



Fig-4 : Images of water pump and Air pumps.

**5. SOFTWARE DESCRIPTION**

The software system consists of upper and lower computer software. the upper computer software is established by Embedded C. It has the function as following: creating the expert system of aquaculture, the expert system will provide suggestions and export controlling signals after analysing data from salve computer; transferring the maximum and minimum value of test access path of slave computer to itself; storing the data from slave computer to database; data compilation, analysis and curve displaying, etc. The Embedded C is used to create the slave computer software, and store it to RAM. Its main functions are getting the data and comparing it with the maximum and minimum value, and the result of comparison will used to control the output device according to the control arithmetic, and at last storing, displaying and uploading the data.

**5.1. Software of Slave Computer**

Which includes data collecting module, data processing module, data displaying module, data storing module, real time controlling module and data communication module. Its flow chart is showed in fig-5.

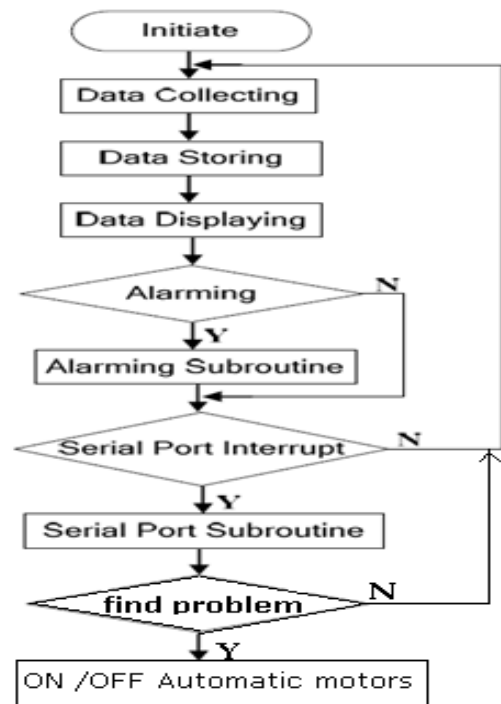

Fig-5: Main program flow chart of slave computer.

**5.2. Software of upper computer**

**Aquaculture Expert System:**

This expert system has a function of predicting, guiding, managing. It can provide expert supports and decisionmaking in different breeding modes and different period according to the aquaculture species, water, environment, etc. Figure-6 is the structure schematics of Expert system.



Fig-6: Expected System

## 6. CONCLUSION

This system can control the real-time aquaculture environment factors and over problem has been raising to play automatic sound alarming with Levels. This levels follow Automatic ON / OFF water pumps & Air pump. water levels far distance, it can accomplish:

- (1) *Product Safe* in automatic controller system to give safe mode in each time
- (2) *Energy saving* Achieved by reducing the working time of oxygen pump through controlling the amount of dissolving oxygen.
- (3) *Lower cost and increase output* Make sure the aquatic products living with comfortable environment in order to reduce disease and reduce the usage of feed.
- (4) *Lower the labour intensity and improve efficiency.*

## ACKNOWLEDGEMENT

The authors are grateful Mr. G. Kalyan Mohan, Associate professor (KLU) for his encouragement and guidance to present/publish this paper. We acknowledge the diligent efforts of our Head of the Department Dr.S.Balaji in assisting us towards implementation of this idea.

## REFERENCES

- [1]. SONG Chang-tai. Water Quality Management Knowledge of Health Culture. Feed Research, vol.1, pp.57~60.2005
- [2]. ZHOU De-qiang, YANG Long-xing. Research on Automatic Control System of Environmental Factors in Aquaculture. Journal of Jiangsu Teachers University of Technology, vol.12(4), pp.34~37, 2006.
- [3]. Vertical integration as an alternative governance structure of value chain quality management: The case of Pangasius industry in the Mekong River Delta, Vietnam-OCT-2007
- [4]. Steve Furber. ARM System-on-Chip Architecture. Addison-Wesley, 2nd edition;2010.
- [5]. David Seal. ARM Architecture Reference Manual. Addison-Wesley, 2nd edition;2010.
- [6]. KE Jing, YANG Shi-feng, HOU Hai-ling. Wireless Monitoring System for Aquiculture Environment. Journal of Tianjin University of Science & Technology, vol22(4), pp.56~59,2007
- [7]. Thomas M. Losordo, Raul H. Piedrahita & James M. Ebeling An Automated Water Quality Data Acquisition System for use in Aquaculture Ponds Aquacultural Engineering 7 (1988) 265-278
- [8]. D.D. Harris, Feng Zhang, P.H. Sydenham; Application of an expert system to monitoring and control in Aquaculture, Volume 4, Issue 3, September 1991, Pages 165-171
- [9]. YIAN Dong, FU Ze-tian, LI Dao-liang, etc. Design on the Freshwater Shrimp Culture Expert System Based-on Web. Application Research of Computers, vol.6, pp.24~25, 2001.
- [10]. Beveridge, M.C.M. (1996). *Cage Aquaculture*, 2nd edn. Fishing News Books, Oxford
- [11]. Tiago Alves and Don Felton. TrustZone: integrated hardware and software security. ARM whitepaper, 2009.

## WEB SITES

- [1]. [www.was.org/](http://www.was.org/)
- [2]. [www.electronicsforu.com/](http://www.electronicsforu.com/)
- [3]. [www.arm.com/](http://www.arm.com/)
- [4]. [www.ichthica.com/](http://www.ichthica.com/)

## BIOGRAPHIES

**Bodepudi SrinivasaRao:** He born in Nuzendla, Andhra Pradesh, India. He is pursuing M.Tech in Embedded System in K.L. University, India. He received B.Tech degree in Electrical & Communication Engineering from Acharya Nagarjuna University- Guntur. His area of interest in Embedded Systems, Research interests include H/w analysis and RFID Technologies.

**U.Jyothi Kameswari:** she born in vijayawada, Andhra Pradesh, India. She is Pursuing Ph.D in k.L. University. She received M.Tech from Acharya Nagarjuna University. Her area of interest in Software Engineering.